



FORKLIFT DRUM CLAMP SINGLE 205L

MODEL NO: **DG02.V2**

Thank you for purchasing a Sealey product. Manufactured to a high standard, this product will, if used according to these instructions, and properly maintained, give you years of trouble free performance.

IMPORTANT: PLEASE READ THESE INSTRUCTIONS CAREFULLY. NOTE THE SAFE OPERATIONAL REQUIREMENTS, WARNINGS & CAUTIONS. USE THE PRODUCT CORRECTLY AND WITH CARE FOR THE PURPOSE FOR WHICH IT IS INTENDED. FAILURE TO DO SO MAY CAUSE DAMAGE AND/OR PERSONAL INJURY AND WILL INVALIDATE THE WARRANTY. KEEP THESE INSTRUCTIONS SAFE FOR FUTURE USE.



Refer to instruction manual

1. SAFETY

- ✓ Forklift trucks should only be used by fully trained personnel.
- ✗ **DO NOT** load more than one drum.
- ✗ **DO NOT** use on drums with removable tops.
- ✓ Ensure jaw mechanism is folded back onto main frame of the Drum Clamp when not in use (removed from forklift truck).
- ✓ Fold back jaw mechanism onto main frame of the Drum Clamp if driving long distances whilst not carrying drums.
- ✗ **DO NOT** overload the Drum Clamp - maximum capacity is **350kg**.
- ✗ **DO NOT** allow others to ride on the Drum Clamp when fitted to forklift.
- ✓ Only use on firm, level, unobstructed surfaces which are capable of supporting the forklift, clamp and a fully loaded drum.
- ✓ Whilst operating the forklift and Drum Clamp ensure a safe distance from other personnel.
- ✓ This product should not be used for moving empty drums.
- ☐ **WARNING:** Failure to comply with these instructions may result in loss of load, damage to forklift and Drum Clamp or other property and/or personal injury.

2. INTRODUCTION

Less manual effort required as hydraulic ram clamps drum, then raises it off the ground for simple manoeuvring and relocation. Cradle is fitted with two smooth-rolling, heavy-duty wheels and one castor with brake. Suitable for 205L drums.

3. SPECIFICATION

Model No:DG02.V2
Capacity:350kg
Drum size:205L
Fork opening:623mm

4. OPERATION

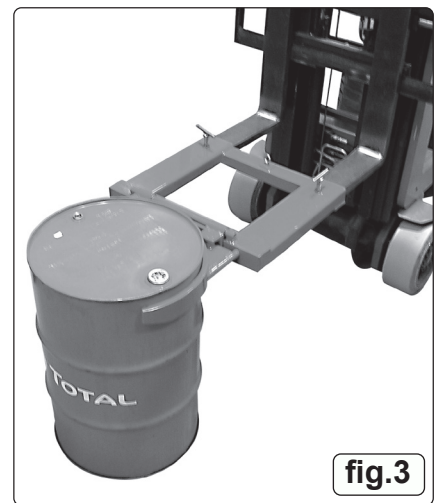

4.1. FITTING THE DRUM CLAMP ONTO A FORKLIFT TRUCK

- 4.1.1. Ensure the forklift truck's forks are the correct distance apart to fit into the Drum Clamp.
- 4.1.2. Drive the forklift forwards enabling the forks to enter the 2 large slots in the Drum Clamp (fig.1) and continue forwards until the forks are fully inserted in the Drum Clamp.
- 4.1.3. Tighten down fully the 2 large T-Bar tightening bolts.
- 4.1.4. If driving a long distance before picking up any drums fold back the operating jaw mechanism onto the main frame of the Drum Clamp. **4.2. PICKING UP A DRUM USING THE DRUM CLAMP**
- 4.1.5. If necessary fold out the jaw mechanism.
- 4.1.6. Drive the forklift slowly towards drum to be picked up, ensuring the Clamp jaws are just above the top of the drum (fig.2). When jaws are above the drum, slowly lower forks and as the jaws are lifted by contact with the drum they will also start to widen out around the drum.
- 4.1.7. Continue to lower the forks, the jaws will slide down over the drum. Lift the forks and the jaws will clamp around the drum just under the top lip (fig.3).
- 4.1.8. Continue to raise the forks to lift the drum off the ground.



4.2. TO RELEASE DRUM FROM THE DRUM CLAMP

- 4.2.1. Lower drum onto ground (fig.4) and continue to lower the forks slowly so clamp jaws slide down the sides of the drum.
- 4.2.2. As the clamp jaws reach the first lip around drum (fig.5), they will begin to lift and as they do this they will also start to widen. Continue to slowly lower forks and as the clamp jaws widen more, also slowly reverse the forklift truck and the drum will be released from the Drum Clamp (fig.6).

5. MAINTENANCE

- 5.1. Store in a safe place with the jaw mechanism folded back onto the main frame so as not to cause an obstruction.
- 5.2. Occasionally lubricate the hinges.



ENVIRONMENT PROTECTION

Recycle unwanted materials instead of disposing of them as waste. All tools, accessories and packaging should be sorted, taken to a recycling centre and disposed of in a manner which is compatible with the environment. When the product becomes completely unserviceable and requires disposal, drain any fluids (if applicable) into approved containers and dispose of the product and fluids according to local regulations.



REGISTER YOUR PURCHASE HERE

Note: It is our policy to continually improve products and as such we reserve the right to alter data, specifications and component parts without prior notice. Please note that other versions of this product are available. If you require documentation for alternative versions, please email or call our technical team on technical@sealey.co.uk or 01284 757505.

Important: No Liability is accepted for incorrect use of this product.

Warranty: Guarantee is 12 months from purchase date, proof of which is required for any claim.

Sealey Group, Kempson Way, Suffolk Business Park, Bury St Edmunds, Suffolk. IP32 7AR

01284 757500

sales@sealey.co.uk

www.sealey.co.uk